

URGENT

MWO effective date is 1 March 2004 and completion date is 1 March 2007.

*MWO 3-4240-325-12-1

MODIFICATION WORK ORDER

**MODIFICATION FOR THE REMOVAL/REPLACEMENT
OF
M48 GAS PARTICULATE FILTER (GPF)
NSN 4240-01-161-3710**

AND

**M48A1 GAS PARTICULATE FILTER (GPF)
NSN 4240-01-363-1311**

(ONLY M48A1 - LOT NUMBERS BEGINNING WITH "P", "PFC", OR "PARMATIC")

Headquarters, Department of the Army, Washington, D.C.

Current as of 22 May 2006

REPORTING ERRORS AND RECOMMENDING IMPROVEMENT

You can help improve this MWO. If you find any mistakes or if you know of a way to improve the procedures, please let us know. Mail your letter or DA Form 2028 (Recommended Changes to Publications and Blank Forms) directly to Commander, U.S. Army Tank-automotive and Armament Command, ATTN: AMSTA-LC-R, 15 Kansas St., Natick, MA 01760-5052. You may also submit your recommended changes by email directly to: <amssbriml@natick.army.mil>. A reply will be provided to you.

*This MWO supersedes MWO 3-4240-325-12-1, dated 22 March 2004.

DISTRIBUTION STATEMENT A – Approved for public release; distribution is unlimited.

1. PURPOSE.

The purpose of this MWO is to ensure the total removal and replacement of M48 Gas-Particulate Filter (GPF) (NSN 4240-01-161-3710) and Parmatic-made M48A1 GPF (NSN 4240-01-363-1311) identified by lot numbers beginning with "P", "PFC", or "PARMATIC" on numerous fielded systems is completed.

2. PRIORITY.

This modification is classified urgent as a result of M48 GPF containing a material that has been determined to be a possible carcinogen, and Parmatic-made M48A1 GPF (identified by lot numbers beginning with "P", "PFC", or "PARMATIC") that are suspect of not providing adequate NBC protection.

3. END ITEM OR SYSTEM TO BE MODIFIED.

The following Army systems shall be modified using this MWO:

NOMENCLATURE	NSN	LIN
M93 Gas-Particulate Filter Unit	4240-01-231-6515	N/A
M1A1 ABRAMS Tank	2350-01-087-1095	T13168
M1A2 ABRAMS Tank	2350-01-328-5964	T13305
M109A6 Paladin, 155mm Howitzer, Medium Self-Propelled	2350-01-305-0028	H57642
M2A3 Bradley Fighting Vehicle	2350-01-436-0005	F60564
Alarm, Biological Agent, Automatic: Integrated Detection System, M31A1 (EIC: 5AQ)	6665-01-436-2309	A48498
SICPS Modular Command Post System (MCPS)	8340-01-323-2454	C40496
AN/TPQ-36 (V) 8 Radar Set (EIC: Q68)	5840-01-390-0529	R14283
AN/TSM-191(V) 3 Transportable Electronic Shop (EIC:KIF)	4940-01-324-1505	T92961
Communications Terminal AN/TRC-179(V)1 (EIC: LMB)	5895-01-156-0411	N/A
Terminal, Tactical S, AN/TSC-124	5895-01-272-1915	N/A
Shop Equipment, Guided Missile, Remote Control	4935-01-282-9256	S14686
Data Analysis Central AN/MYQ-6	5895-01-322-6485	N/A
Shelter, Nonexpendable, Integrated LP/PD1-90	5411-01-333-0663	R98145
Net Control Station, AN/TSQ-158 (V)2	5895-01-359-9010	N/A
Net Control Station	5895-01-423-9141	N/A
Shop Equipment, Guided Missile Repair Remote Control	4935-01-378-0083	S25749

NOMENCLATURE	NSN	LIN
Communication Control Set AN/TSQ-182	5895-01-396-6170	C90531
Net Control Station	5895-01-423-9141	N/A
Shop Equipment, Guided Missile Repair Remote Control	4935-01-378-0083	S25749
Communication Control Set AN/TSQ-182	5895-01-396-6170	C90531
Communication Control Set AN/TSQ-184A	5895-01-387-5620	C90735
Communication Control Set AN/TSQ-183A	5895-01-387-5792	C90599
Tank, Combat, Full Tracked	2350-01-369-3489	N/A
Carrier, Bridge Launching, M104 Wolverine	5420-01-430-5403	N/A
Shelter, Non-expandable, Lightweight, Multi-Purpose, S-832/G	5411-01-436-3326	N/A
Target Acquisition Subsystem, AN/TSQ-179 (V)1	5865-01-437-4914	N/A
Radar Set AN/TPN31	5840-01-450-8126	R17126

4. MODULE(S) (COMPONENTS, ASSEMBLIES, SUBASSEMBLIES) TO BE MODIFIED.

NOMENCLATURE	NSN	PART NUMBER	LOT NUMBER
M48 Gas-Particulate Filter	4240-01-161-3710	E5-19-7436	ALL
M48A1 Gas-Particulate Filter	4240-01-363-1311 (Parmatic Filter Corp)	5-19-7435	Beginning with "P", "PFC", or "PARMATIC"

5. PARTS TO BE MODIFIED.

Not Applicable.

6. APPLICATION.

a. Time Compliance Schedule. The MWO effective date is 1 March 2004 and the completion date is 1 March 2007.

b. Level of Maintenance. Operator and Unit Level.

c. Application Time. The total man-hours required for a single application of this MWO is 1 to 3 hours depending on end item.

d. This MWO does not effect any other MWO or upgrade.

7. TECHNICAL PUBLICATIONS AFFECTED/CHANGED.

Not Applicable.

8. MWO KIT(S)/PARTS(S) AND THEIR DISPOSITION.

a. Kit(s)/Part(s) Needed to Apply the MWO.

NOMENCLATURE	NSN	PART NUMBER	LOT NUMBER
M48A1 Gas-Particulate Filter	4240-01-363-1311	5-19-7435	Beginning with "SXE"

b. Contents of MWO Kits.

- (1) Bags for Disposal (M48 Only) 20" x 30" Poly Bag
- (2) Zip Ties

c. Bulk and Expendable Material.

Not. Applicable.

d. Parts Disposition.

M48

The M48 carbon is considered hazardous waste. Classify all displaced M48 GPF as condition code "H" and dispose of IAW local procedures for hazardous waste. Contact your installation environmental office for further information.

M48A1

Classify all displaced Parmatic-made M48A1 GPF (identified by lot numbers beginning with "P", "PFC", or "PARMATIC") as condition code "L" and return to Blue Grass Army Depot. Shipping address is:

XU General Supply Storage Point
 Blue Grass Army Depot (DODAAC: W22PVJ)
 ATTN: Allen Ferrell
 2091 Kingston HWY
 Richmond, KY 40475-5000

NOTE

Return M48A1 filters in the shipping container from the replacement filters. Email M48-M48A1GPF@ria.army.mil to request a transportation fund cite.

9. SPECIAL TOOLS; TOOL KITS; JIGS; TEST, MEASUREMENT AND DIAGNOSTIC EQUIPMENT (TDME); AND FIXTURES REQUIRED.

Not Applicable.

10. MODIFICATION PROCEDURES.

See the following Appendices:

- B – M93 and All Associated Systems.
- C – M1A1/M1A2/M1A2 SEP Tanks
- D – M109A6 Paladin
- E – M2A3 Bradley Fighting Vehicle

11. CALIBRATION REQUIREMENTS.

Not Applicable.

12. WEIGHT AND BALANCE DATA.

Not Applicable.

13. QUALITY ASSURANCE REQUIREMENTS.

Not Applicable.

14. RECORDING AND REPORTING OF THE MODIFICATION PROGRAM.

NOTE

Submit below information for every filter whether replaced or not. Some M48A1 filters need not be replaced. Only PARMATIC-MADE M48A1 GPF NSN 4240-01-363-1311, Lot Numbers beginning with “P”, “PFC”, or “PARMATIC” must be replaced.

The organization responsible for MWO application will report application information as follows:

Submission will be comprised of the data elements listed in the table below. Elements 1 and 2 are given for this MWO (as shown). Submit the application data (information requested in data elements below) by email to: M48-M48A1GPF@ria.army.mil. An MWO recording form is provided in Appendix F.

NO.	DATA ELEMENT	INPUT DATA
1	Material Change Number	1-03-08-0002
2	MWO Number	3-4240-325-12-1
3	Unit Name	
4	Unit UIC	
5	Repair Location	
6	End Item NSN	
7	End Item Nomenclature	
8	End Item Serial Number (if applicable)	
9	Registration # (if applicable)	
10	Filter (#1): M48 or M48A1, check one	<input type="checkbox"/> M48 <input type="checkbox"/> M48A1
11	Filter (#1) Lot No. (NA if M48)	
12	Was filter (#1) replaced?	
13	If filter (#1) is replaced, note Lot No. of new filter	
14	Filter (#2) NSN (if applicable): M48 or M48A1, (check one)	<input type="checkbox"/> M48 <input type="checkbox"/> M48A1
15	Filter (#2) Lot No. (if applicable) (NA if M48)	
16	Was filter (#2) replaced?	

NO.	DATA ELEMENT	INPUT DATA
17	If filter (#2) is replaced, note Lot No. of new filter	
18	Date of Application	
19	Man Hours Required	
20	Applied By (i.e., LAR, unit, contractor, team)	

15. MATERIAL CHANGE (MC) NUMBER.

This MWO is authorized by MC number 1-03-08-0002.

16. MODIFICATION IDENTIFICATION.

Inspect equipment, if the M48A1 GPF (NSN 4240-01-363-1311) with a lot number other than "P", "PFC", or "PARMATIC" is installed, no filter change is needed.

APPENDIX A

REFERENCES

D.1 SCOPE.

This appendix lists all forms, field manuals, technical manuals and miscellaneous publications referenced in this MWO.

D.2 FORMS.

DA FORM 2028 Recommended Changes to Publications and Blank Forms

D-3. FIELD MANUALS.

FM 3-11.4 NBC Protection

FM 3-11.5 NBC Decontamination

D-4. TECHNICAL MANUALS.

TM 3-6665-307-10 Chemical Agent Detector Kit, M256 and M256A1

TM 9-2350-288-10 Operator's Manual Tank, Combat, Full-Tracked; 120mm M1A2, General
Abrams

TM 9-2350-294-20-1-5 Fighting Vehicle, Infantry, M2A3, and Fighting Vehicle, Cavalry, M3A3, Hull

TM 9-2350-314-10 Howitzer, Medium, Self-Propelled; 155MM, M109A6

APPENDIX B**MODIFICATION PROCEDURES FOR M93 GAS-PARTICULATE FILTER UNIT****M48/M48A1 GAS-PARTICULATE FILTER CANISTER REPLACEMENT FOR M93**

Initial Setup - Tools: General Mechanic's Tool Kit SC 5180-90-N26

Equipment Condition: Ballistic Cover Open
Filter Cover Assembly Removed

Materials/Parts: Plastic Bag
Zip Tie

References: FM 3-11.4 and FM 3-11.5

REMOVAL**WARNING**

Personal injury or death may occur when handling contaminated filters. The unit commander or senior officer in charge of maintenance personnel, assigned to remove and dispose of the contaminated or outdated gas particulate filter canister, must prescribe the necessary safety measures to follow. This includes NBC decontamination (FM 3-11.5) that must be performed before a new filter canister is installed. He/she must also prescribe the necessary protective clothing (FM 3-11.4) to wear during this operation.

NBC – contaminated air filters must be handled and disposed of only by authorized and trained personnel. The unit commander or senior officer in charge of maintenance personnel must ensure that prescribed protective clothing (FM 3-11.4) is used and prescribed safety measures and decontamination procedures (FM 3-11.5) are followed. The local unit SOP is responsible for final disposal of contaminated air filters. Failure to comply may cause severe injury or death to personnel.

1. Loosen nut (1) and remove assembled clamp grooved coupling (2) (see figure B-1).
2. Loosen hose clamp (3) and remove outlet transition (4) from filter canister (5).
3. Remove two bolts (6) and washers (7), securing retaining strap (8) to support bracket (9).
4. Remove assembled filter canister (5) from shelter inlet by lifting it from its seal in support bracket (9).
5. Remove M48/M48A1 filter.
6. Place filter in plastic bag and seal with a zip tie and label bag.
7. Dispose of M48 filters IAW local procedures for hazardous waste. M48A1 filters are to be turned in IAW paragraph 8.
8. Record filter information per paragraph 14.

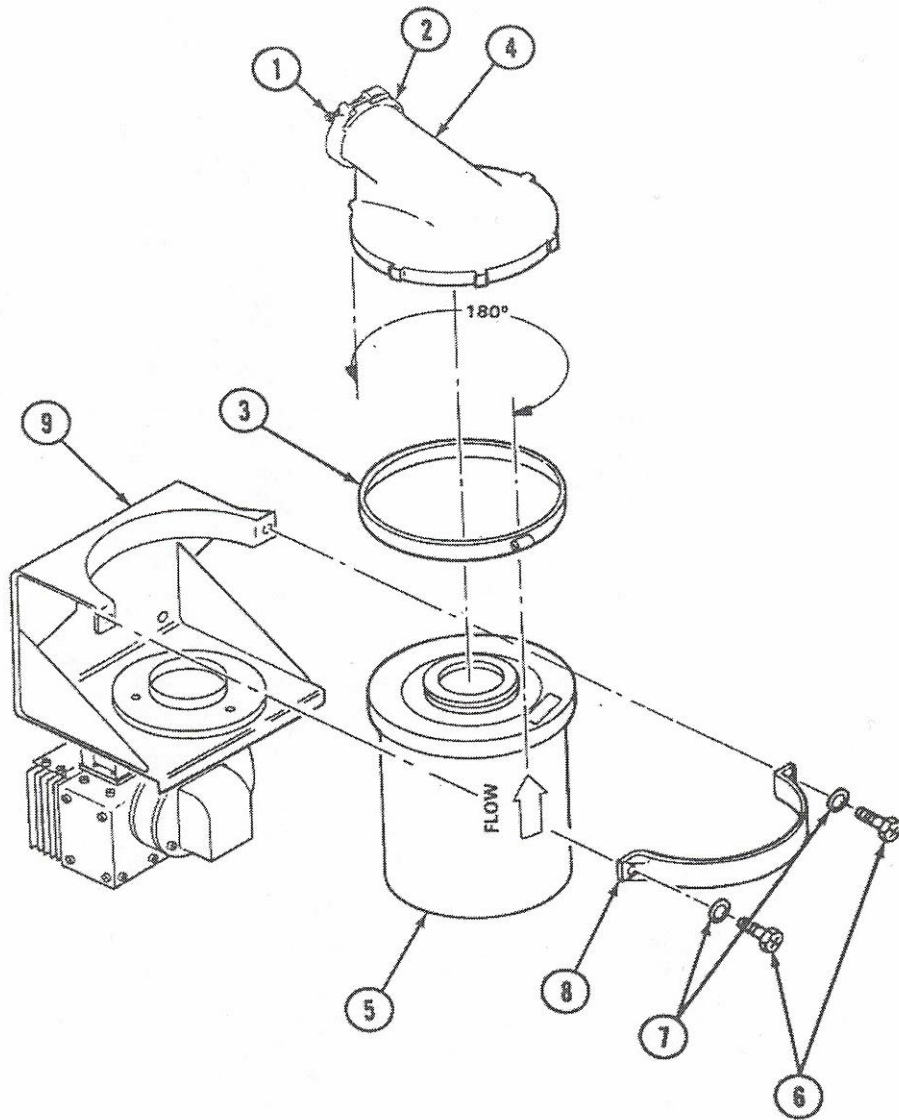

Figure B-1.

INSPECTION

1. Inspect support collar (1) on support bracket (2) (see figure B-2). Replace if damaged or worn.

WARNING

Dry cleaning solvent emits strong vapors and is highly flammable. Use in a well ventilated area away from sparks and open flames. Failure to observe this precaution could result in serious injury or death.

2. Using dry cleaning solvent and wiping rags clean support collar (1) to ensure that it is free of dirt, grease or other contaminants.
3. Inspect rubber strips (3) on retaining strap (4) and support bracket (2). Replace if worn, torn, hardened, loose, or otherwise damaged.

INSTALLATION

1. Mark installation date on M48A1 filter canister identification plate (5) in space provided (see figure B-2).
2. Secure outlet transition (6) to filter canister (7) with hose clamp (8).
3. Place filter canister (7) on support collar (1) so that flow arrow is visible and pointing up toward outlet transition (6) (see figure B-3).
4. Position assembled filter canister (7) and outlet transition (6) in support bracket (2), ensuring outlet transition aligns with shelter inlet. Ensure filter canister (7) seats properly on support collar (1).
5. Secure retaining strap (4) to support bracket (2) using two bolts (11) and washers (12).
6. Position assembled clamp grooved coupling (9) and outlet transition (6) on shelter inlet, and secure by tightening nut (10) (see figure B-3).

NOTE

After installation of new gas filter, an ammonia smell will be present. This is a normal occurrence and does not indicate a bad filter or create a health hazard. Operate unit for approximately 1 hour to eliminate odor.

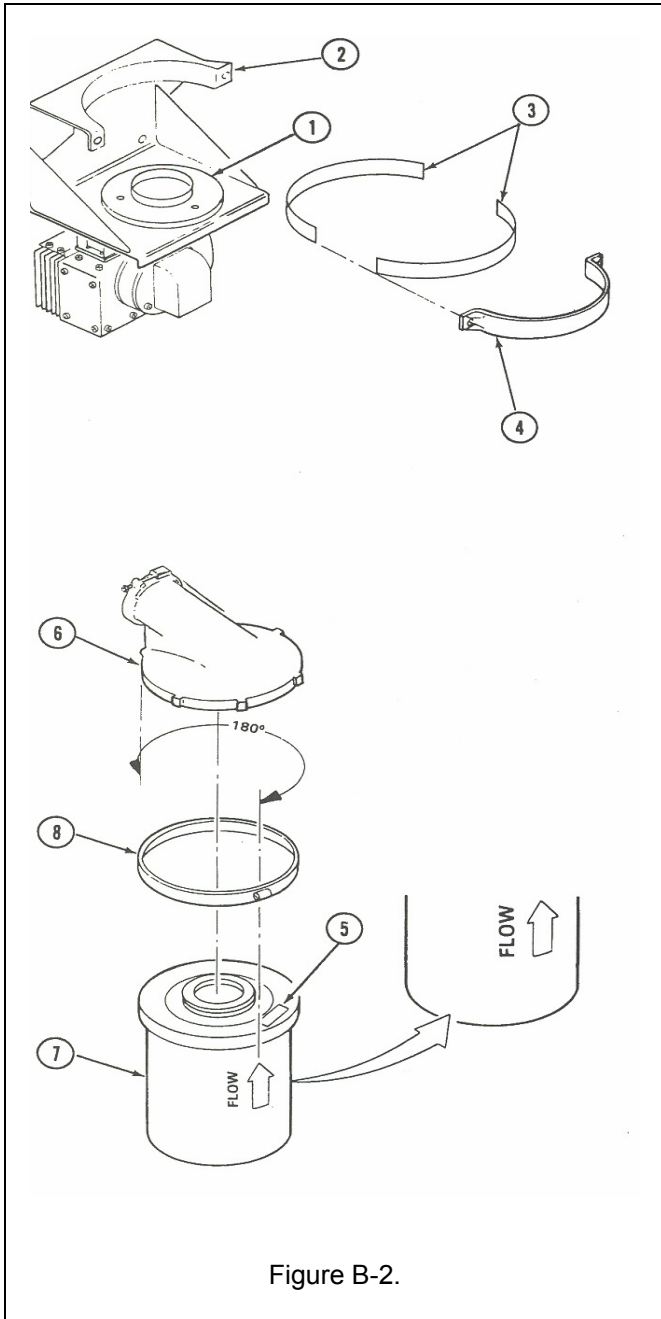

Figure B-2.

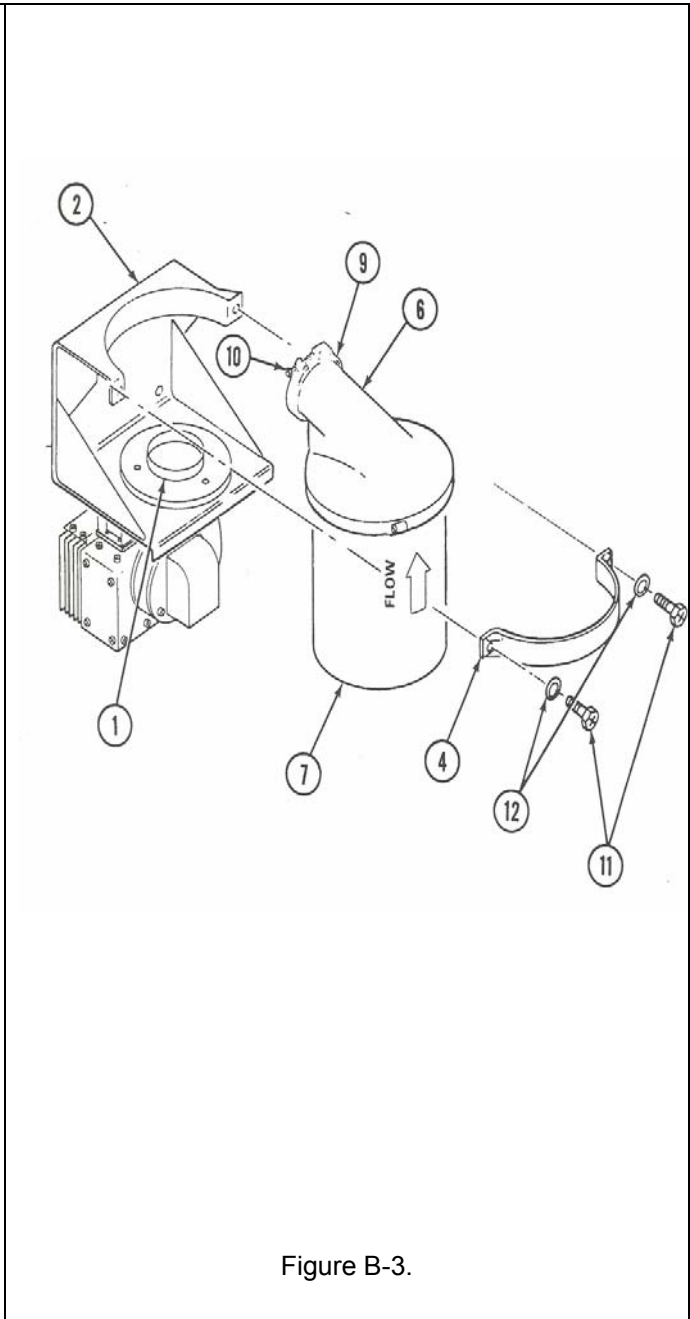

Figure B-3.

APPENDIX C**MODIFICATION PROCEDURES FOR M1A1/M1A2/M1A2 SEP TANKS****M48/M48A1 GAS-PARTICULATE FILTER REPLACEMENT FOR M1A1/M1A2/M1A2 SEP TANKS**

Initial Setup - Tools: General Mechanic's Tool Kit SC 5180-90-N26

Equipment Condition: Outlet air exhaust manifold removed

Materials/Parts: Plastic Bag
Zip Tie

References: FM 3-11.4 and FM 3-11.5

REMOVAL**WARNING**

Personal injury or death may occur when handling contaminated filters. The unit commander or senior officer in charge of maintenance personnel, assigned to remove and dispose of the contaminated or outdated gas particulate filter canister, must prescribe the necessary safety measures to follow. This includes NBC decontamination (FM 3-11.5) that must be performed before a new filter canister is installed. He/she must also prescribe the necessary protective clothing (FM 3-11.4) to wear during this operation.

NBC – contaminated air filters must be handled and disposed of only by authorized ad trained personnel. The unit commander or senior officer in charge of maintenance personnel must ensure that prescribed protective clothing (FM 3-11.4) is used and prescribed safety measures and decontamination procedures (FM 3-11.5) are followed. The local unit SOP is responsible for final disposal of contaminated air filters. Failure to comply may cause severe injury or death to personnel.

1. Remove two filters by sliding each filter (1) slightly from support (2) (see figure C-1).
2. Place each filter in plastic bag, seal bag with zip tie, and label each bag.
3. Dispose of M48 filters IAW local procedures for hazardous waste. M48A1 filters are to be turned in IAW paragraph 8.
4. Record filter information per paragraph 14.

INSTALLATION

1. Inspect for seal (1) inside of M48A1 filter (2) (see figure C-2).
2. Position each filter (3) on support (4). Position filter label on top to see over manifold.
3. Install outlet air exhaust manifold.

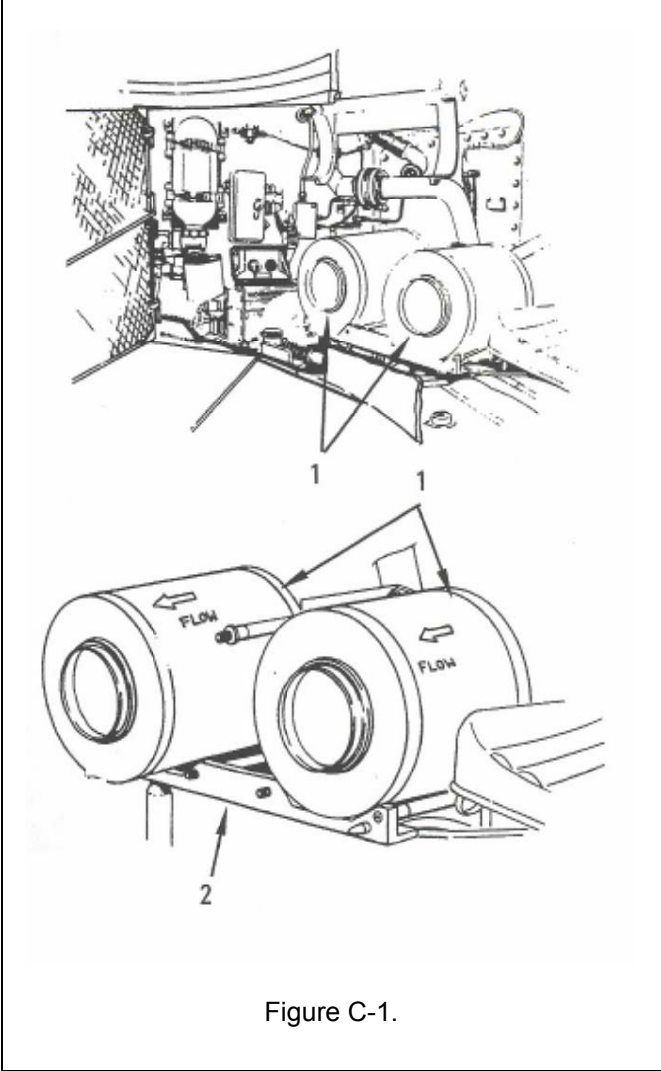

Figure C-1.

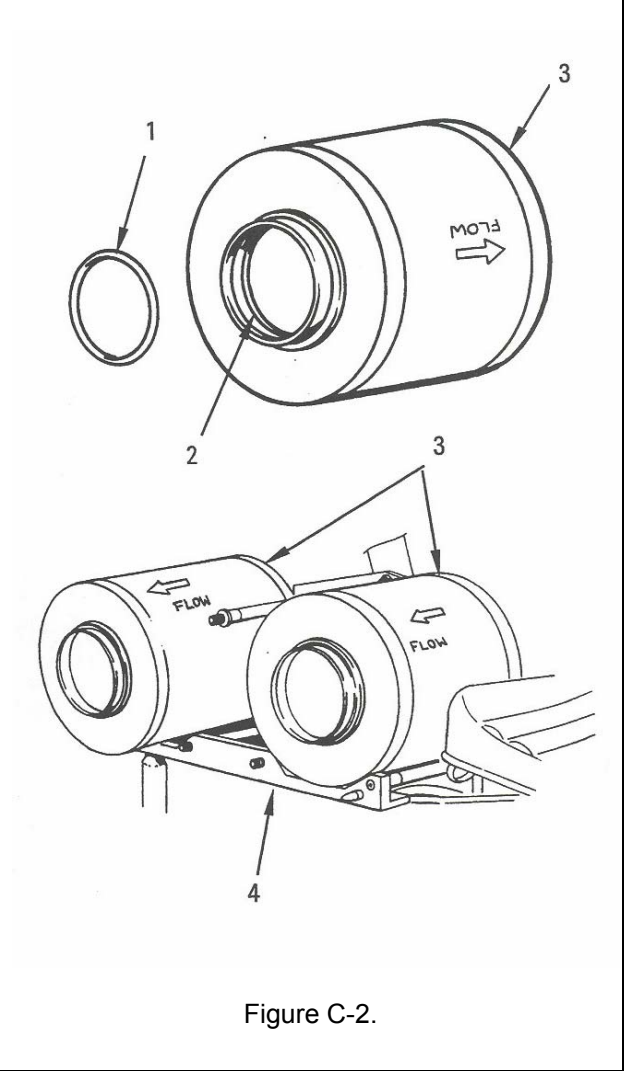

Figure C-2.

APPENDIX D

MODIFICATION PROCEDURES FOR M109A6 PALADIN

M48/M48A1 GAS-PARTICULATE FILTER REPLACEMENT FOR M109A6 PALADIN

Initial Setup - Tools: Artillery and Turret Mechanic's Tool Kit SC 5180-95-A12

Equipment Condition: Ballistic Cover Open
Filter Cover Assembly Removed

Materials/Parts: Plastic Bag
Zip Tie

References: FM 3-11.4 and FM 3-11.5

WARNING

Personal injury or death may occur when handling contaminated filters. The unit commander or senior officer in charge of maintenance personnel, assigned to remove and dispose of the contaminated or outdated gas particulate filter canister, must prescribe the necessary safety measures to follow. This includes NBC decontamination (FM 3-11.5) that must be performed before a new filter canister is installed. He/she must also prescribe the necessary protective clothing (FM 3-11.4) to wear during this operation.

NBC – contaminated air filters must be handled and disposed of only by authorized and trained personnel. The unit commander or senior officer in charge of maintenance personnel must ensure that prescribed protective clothing (FM 3-11.4) is used and prescribed safety measures and decontamination procedures (FM 3-11.5) are followed. The local unit SOP is responsible for final disposal of contaminated air filters. Failure to comply may cause severe injury or death to personnel.

REMOVAL

1. Open MCS access door (see figure D-1).
2. Remove five screws (1), five flat washers (2), tag (3), if installed, and filter access cover (4).
3. Set retractable filter inlet support (5) to unlocked position.
4. Carefully lift up M48/M48A1 filter (6) and place in plastic bag, seal bag with zip tie, and label bag.
5. Dispose of M48 filters IAW local procedures for hazardous waste. M48A1 filters are to be turned in IAW paragraph 8.
6. Record filter information per paragraph 14.

INSTALLATION

1. Install M48A1 filter (6), aligning holes at both ends of filter with filter inlet supports (5).
2. Position filter label to the top.
3. Turn retractable filter inlet support (5) to locked position, making sure that support engages filter (6).
4. Install filter access cover (4) and tag (3), if removed, with five flat washers (2) and five screws (1).

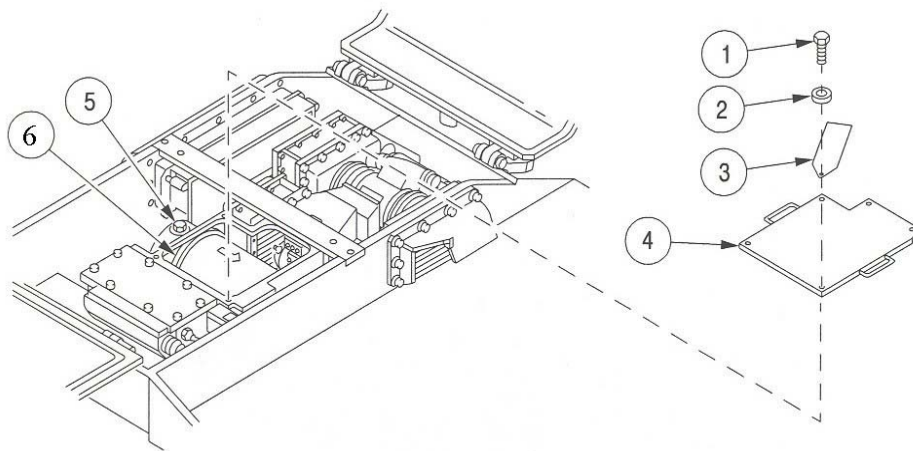

Figure D-1.

APPENDIX E

MODIFICATION PROCEDURES FOR M2A3 BRADLEY FIGHTING VEHICLE

M48/M48A1 GAS-PARTICULATE FILTER REPLACEMENT FOR M2A3 BRADLEY FIGHTING VEHICLE

Initial Setup - Personnel Required: ITV/IFV/CFV System Mechanic 63T10

Tools and Special Tools: General mechanic's tool kit: automotive
(TM 9-2350-294-20-1-5, WP 0863 00, Item 58)

Materials/Parts: Lock washer (6)

Equipment Condition: Engine stopped (TM 9-2350-294-10-1)

References: TM 9-2350-294-10-1

WARNING

Personal injury or death may occur when handling contaminated filters. The unit commander or senior officer in charge of maintenance personnel, assigned to remove and dispose of the contaminated or outdated gas particulate filter canister, must prescribe the necessary safety measures to follow. This includes NBC decontamination (FM 3-11.5) that must be performed before a new filter canister is installed. He/she must also prescribe the necessary protective clothing (FM 3-11.4) to wear during this operation.

NBC – contaminated air filters must be handled and disposed of only by authorized ad trained personnel. The unit commander or senior officer in charge of maintenance personnel must ensure that prescribed protective clothing (FM 3-11.4) is used and prescribed safety measures and decontamination procedures (FM 3-11.5) are followed. The local unit SOP is responsible for final disposal of contaminated air filters. Failure to comply may cause severe injury or death to personnel.

REMOVAL

1. Stow driver's seat. See TM 9-2350-294-10-1.
2. Remove hose (1) from blower (2) and precleaner (3).
 - a. Loosen two clamps (4) and remove hose (1) from blower (2) and precleaner (3). Remove two clamps from hose.

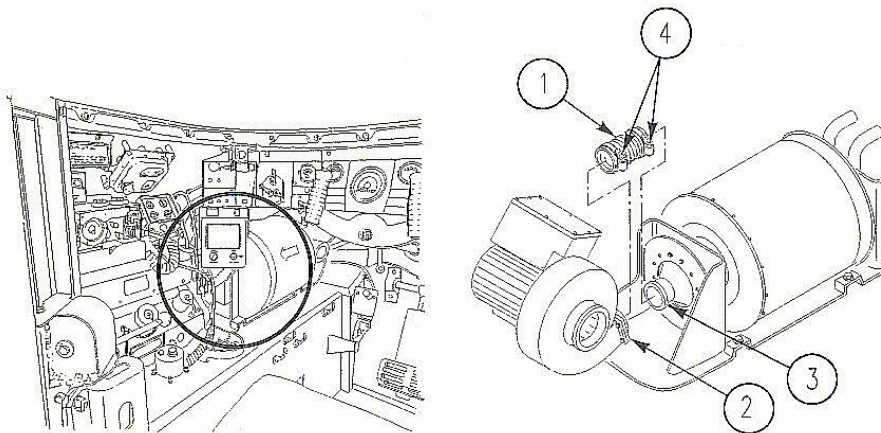

Figure E-1.

REMOVAL-Continued

3. Remove precleaner/flange assembly (1) from bracket (2).
 - a. Remove two jamnuts (3) from studs (4) on precleaner/flange assembly (1).
 - b. Remove precleaner/flange assembly (1) from bracket (2). Clean dirt and dust from precleaner.

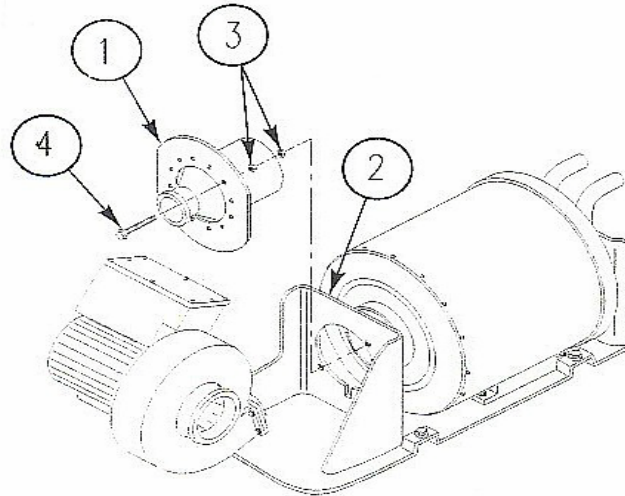

Figure E-2.

4. Remove M48 filter (1) from bracket (2). Clean mating surface of bracket.

NOTE

If replacing precleaner or flange, do step 5 and installation step 1.

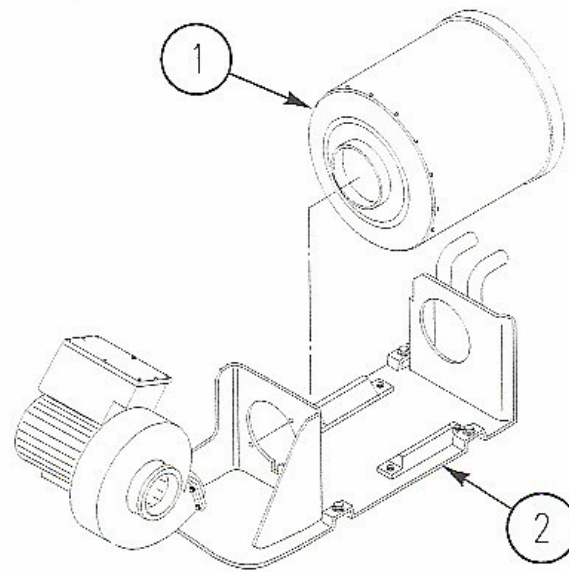

Figure E-3.

5. Remove flange (1) from precleaner (2).

a. Remove six screws (3), lock washers (4), nuts (5) and flange (1) from precleaner (2). Discard lock washers.

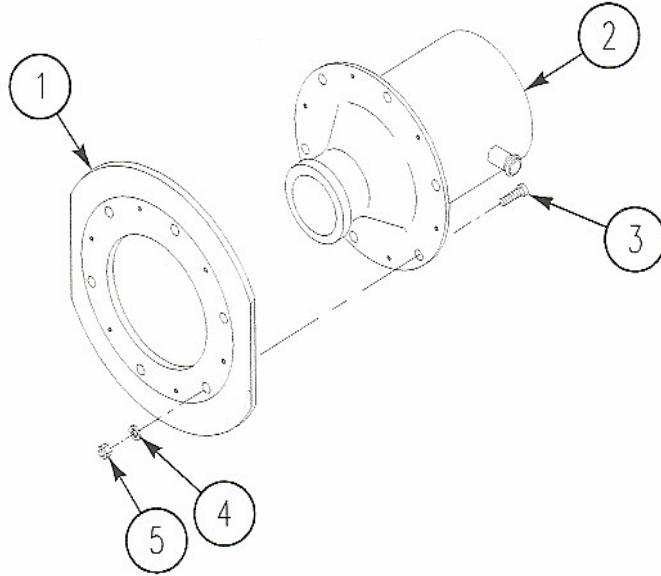

Figure E-4.

INSTALLATION

1. Install flange (1) on precleaner (2).

a. Install flange (1) six screws (3), new lock washers (4), and nuts (5) on precleaner (2).

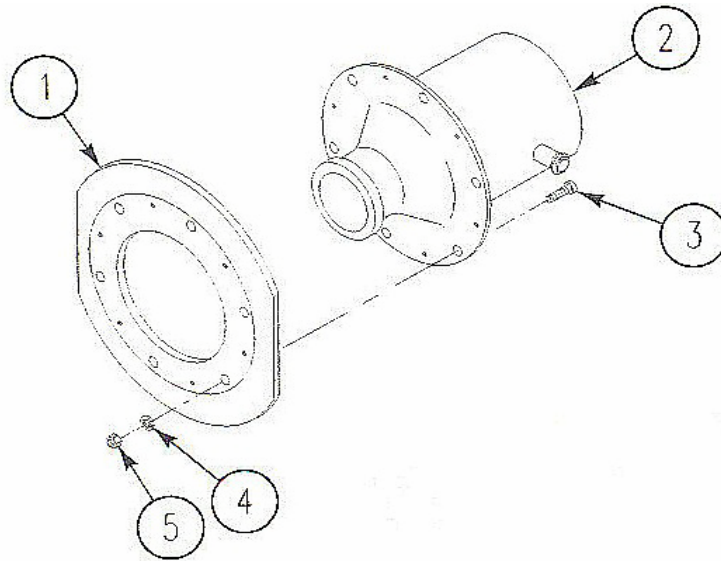

Figure E-5.

INSTALLATION- Continued

2. Install M48A1 filter (1) on bracket (2).

b. With arrow on M48A1 filter (1) pointing toward rear of vehicle, position M48A1 filter on bracket (2). Position filter label to the top to be visible. Align seal on M48A1 filter with mating surface on bracket.

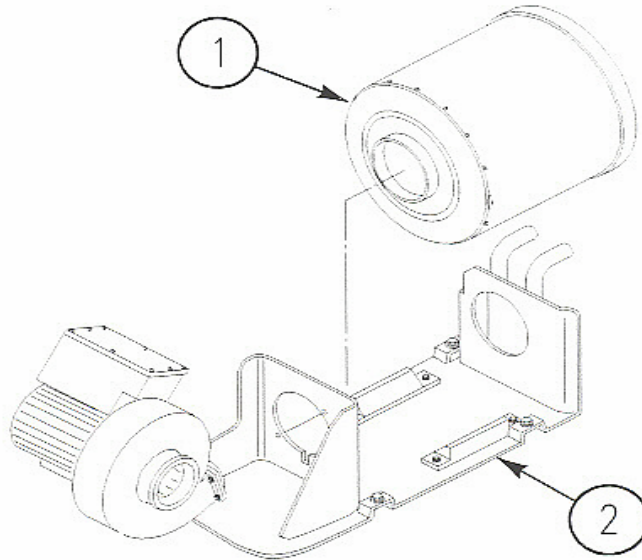

Figure E-6.

3. Install precleaner/flange assembly (1) on bracket (2) and M48A1 filter (3).

a. Position two studs (4) on precleaner/flange assembly (1) into holes in bracket (2). Install two jamnuts (5) on studs.

b. Insert mating surface of precleaner (1) onto M48A1 filter (3).

c. Alternately tighten two jamnuts (5) ensuring filter seal and its mating surface are aligned.

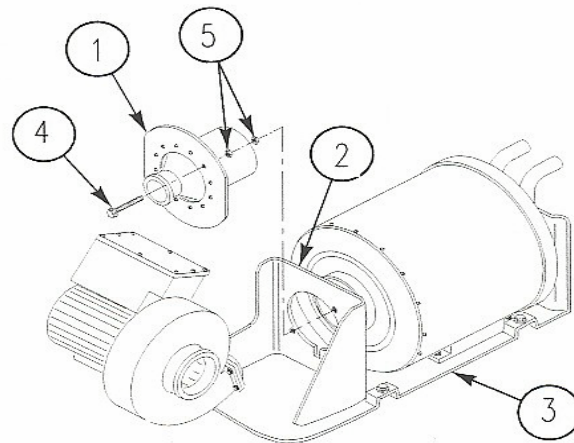

Figure E-7.

4. Install hose (1) on blower (2) and precleaner (3).
 - a. Install two clamps (4) on hose (1).
 - b. Install hose (1) with two clamps (4) on blower (2) and precleaner (3). Tighten clamps.

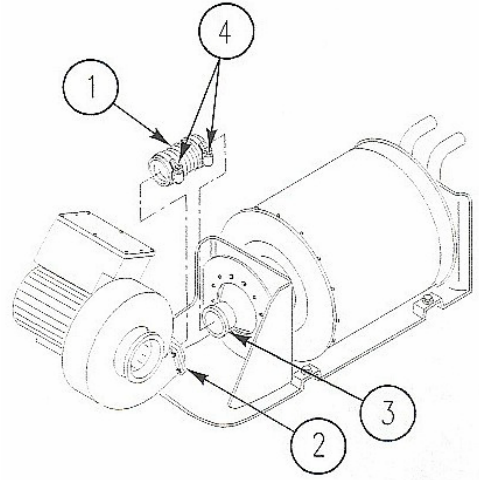

Figure E-8.

5. Install driver's seat. See TM 9-2350-294-10-1.

APPENDIX F

RECORDING AND REPORTING OF MODIFICATION FORM

NO.	DATA ELEMENT	INPUT DATA
1	Material Change Number	1-03-08-0002
2	MWO Number	3-4240-325-12-1
3	Unit Name	
4	Unit UIC	
5	Repair Location	
6	End Item NSN	
7	End Item Nomenclature	
8	End Item Serial Number (if applicable)	
9	Registration # (if applicable)	
10	Filter (#1): M48 or M48A1, check one	<input checked="" type="checkbox"/> M48 <input type="checkbox"/> M48A1
11	Filter (#1) Lot No. (NA if M48)	
12	Was filter (#1) replaced?	
13	If filter (#1) is replaced, note Lot No. of new filter	
14	Filter (#2) NSN (if applicable): M48 or M48A1, (check one)	<input checked="" type="checkbox"/> M48 <input type="checkbox"/> M48A1
15	Filter (#2) Lot No. (if applicable) (NA if M48)	
16	Was Filter (#2) replaced?	
17	If filter (#2) is replaced, note Lot No. of new filter	
18	Date of Application	
19	Man Hours Required	
20	Applied By (i.e., LAR, unit, contractor, team)	

RECORDING AND REPORTING OF MODIFICATION FORM

NO.	DATA ELEMENT	INPUT DATA
1	Material Change Number	1-03-08-0002
2	MWO Number	3-4240-325-12-1
3	Unit Name	
4	Unit UIC	
5	Repair Location	
6	End Item NSN	
7	End Item Nomenclature	
8	End Item Serial Number (if applicable)	
9	Registration # (if applicable)	
10	Filter (#1): M48 or M48A1, check one	<input checked="" type="checkbox"/> M48 <input type="checkbox"/> M48A1
11	Filter (#1) Lot No. (NA if M48)	
12	Was filter (#1) replaced?	
13	If filter (#1) is replaced, note Lot No. of new filter	
14	Filter (#2) NSN (if applicable): M48 or M48A1, (check one)	<input checked="" type="checkbox"/> M48 <input type="checkbox"/> M48A1
15	Filter (#2) Lot No. (if applicable) (NA if M48)	
16	Was Filter (#2) replaced?	
17	If filter (#2) is replaced, note Lot No. of new filter	
18	Date of Application	
19	Man Hours Required	
20	Applied By (i.e., LAR, unit, contractor, team)	

By Order of the Secretary of the Army:

PETER J. SCHOOMAKER
General, United States Army
Chief of Staff

Official:

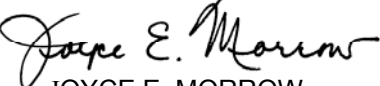
JOYCE E. MORROW
**Administrative Assistant to the
Secretary of the Army**
0614309

Distribution: This publication is available in electronic media only.

